

HALFPIPE PLANS



Includes plans for a
4' Inline Skate Halfpipe,
3' Skateboard Halfpipe and a
Grinding Rail

www.rickdahlen.com
rick@rickdahlen.com

Materials List and Directions

- 7 4 x 8 x 3/4" Exterior Plywood (sanded one side)
- 8 4 x 8 x 3/8" Exterior Plywood (sanded one side)
- 59 2 x 4 x 8 Studs for skateboard version, 61 for the inline version
(18 of these should be pressure treated or sealed if you are choosing to put halfpipe on ground)
- 5-6 lbs 2" Galvanized Wood Deck Screws
- 5-6 lbs 3" Galvanized Wood Deck Screws
- 16 3" Lag Screws
- 16 1 1/4" Washers
- 16 1 - 1 1/4" Panhead Screws
- 2 1 1/2 ID PVC Pipe 8' (you can use metal pipe if you prefer)

All measurements are exact, except where I refer to 2x4. This is a standard name for studs that are actually 1 1/2 x 3 1/2.

1. Measure and cut one curved end piece. Use this one to trace the other seven curved ends. (SEE PLAN A or B).
2. Mark out where the cross joists are positioned on the curved end pieces. Double check the position of the double joist for the plywood decking seam. (SEE PLAN C).
3. Measure and cut cross joists for the four curved end structures. I used pressure treated 2x4's for the two bottom cross joists that touch the ground.
4. Assemble the four curved structures. The plywood tends to bow a little after it is cut. Try to pick two pieces with opposing bows for each of the curved sections. Start by attaching the cross joists at the top of the curved ends. **PREDRILLING THE HOLES IN THE PLYWOOD HELPS!** Use two 3" screws at each end. **DO NOT ATTACH DECKING AT THIS TIME.** (SEE PLAN D).
5. Assemble the frame for the bottom flat decking using 3" screws. I have provided two versions of the framework. One if your halfpipe is going to be on a hard flat surface and one if it is going to be on a slightly uneven or soft ground. **DO NOT ATTACH DECKING AT THIS TIME.** (SEE PLAN E or F).
6. Position your curved end structures and flat frame together where they will remain. (SEE PHOTO BELOW). Use 3" screws to fasten the pieces together. Screw the two curved ends together. Attach them to the flat framework, then fasten it to the two curved structures on other end. **DRILL VENT HOLES IN EACH OF THE ROWS** (SEE PLAN E or F).
7. Using the 2" screws attach the two 4 x 8 x 3/4" sheets of plywood (smooth side up) to the flat framework. **Screw spacing should be approximately 6 - 8" apart.** Note the plywood grain is going from side to side. I feel it provides less chance of splinters. Predrilling was not necessary here.
8. Attach the coping on the corners of the curved ends with the panhead screws. (SEE PLAN G or H). I did it at this time because I could stand in between the joists. I laid the PVC pipe on the ground and drilled my first eight holes from the top straight through the bottom being careful to keep the drill at the same angle for all the holes. The first drilling was just big enough for the screw to enter. I then redrilled just the top hole so I could get my screwdriver through the hole. With the PVC pipe in position, using a **MAGNETIC** screwdriver, I inserted the screw through the top hole down to the bottom hole in the wood. (SEE PLAN G or H).
9. Wet the back side (not the smooth side) of the 4 x 8 x 3/8" plywood. It will curl a little aiding in attaching it to the curved ends. Put the bottom one on first with grain going from side to side. Attach the next bottom panel beside it. You may premeasure and cut this panel before attaching it, or attach it and then trim it in position just below the coping. Be careful you don't cut the coping though. Repeat the procedure for the next layer and the other side. (SEE PLAN J). If you premeasure, note that the second layer top panel is slightly wider than the one below. (SEE PLAN G or H). The curved decking is made of two layers of 3/8" plywood because it is bendable and you need 3/4" total thickness. I did not use as many screws on the bottom layer because I knew the top layer screws would do the job for both layers.
10. Measure and attached the top platform decking using 2" screws.
11. Measure, cut and attach the vertical supports for the railing. I used a couple of clamps to hold them while I screwed then in place. The horizontal supports were attached using two 3" wood screws at each cross over. After it was all together I drilled holes and used the 3" lag screws and washers to anchor the railing. (SEE PLAN K).
12. You can paint it whenever you feel like it. This will give it added protection from the elements.



Frames put together before attaching the decking.

SKATE BOARD HALEPIPE TRANSITION CURVE (PLAN A)

I think the best way to get all curves the same is cut one and use it as a template to draw the others.
For an eight foot wide halfpipe you will need eight curved ends

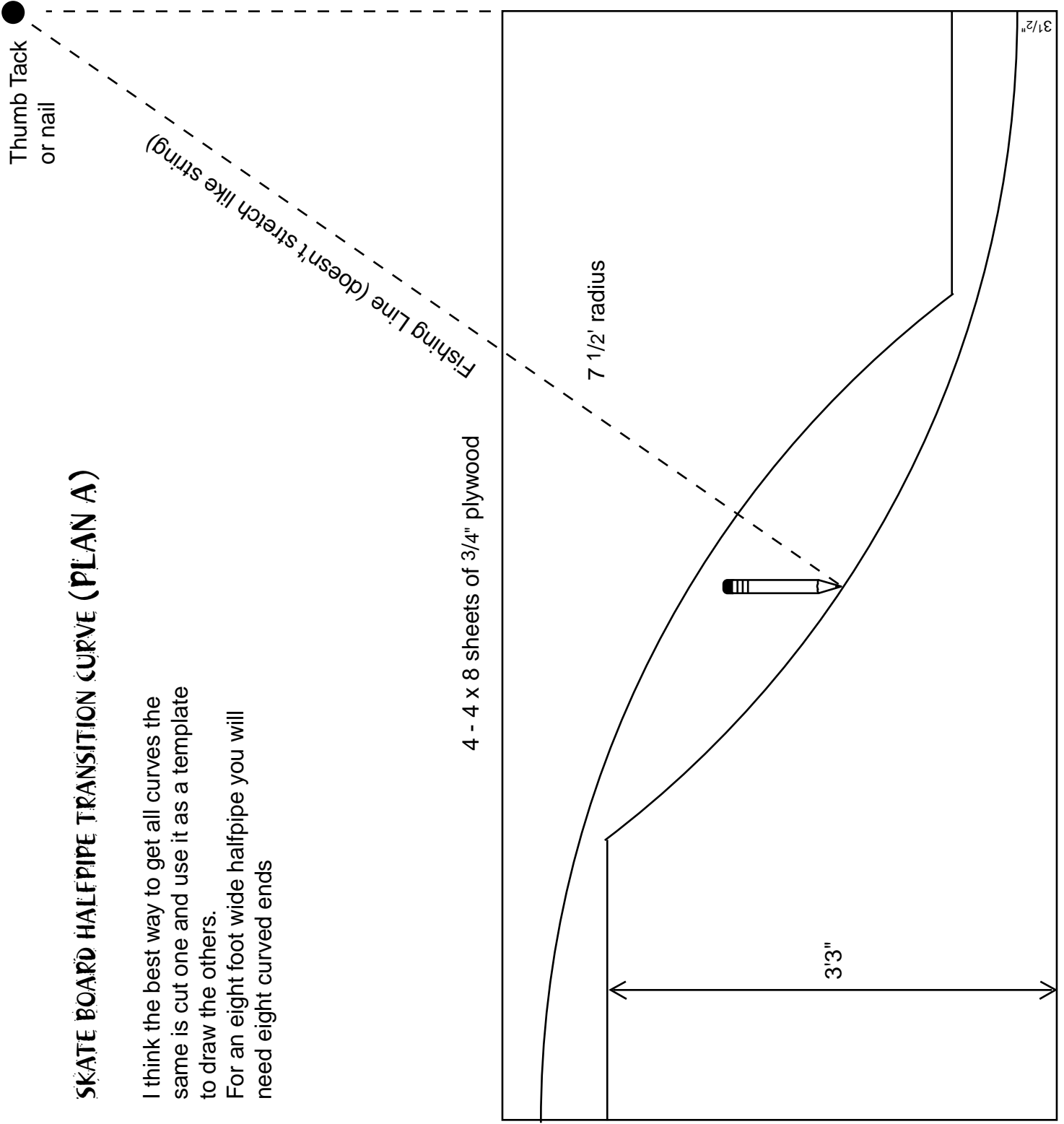

INLINE SKATE HALFPIPE TRANSITION CURVE (PLAN B)

I think the best way to get all curves the same is cut one and use it as a template to draw the others.
For an eight foot wide halfpipe you will need eight curved sides.

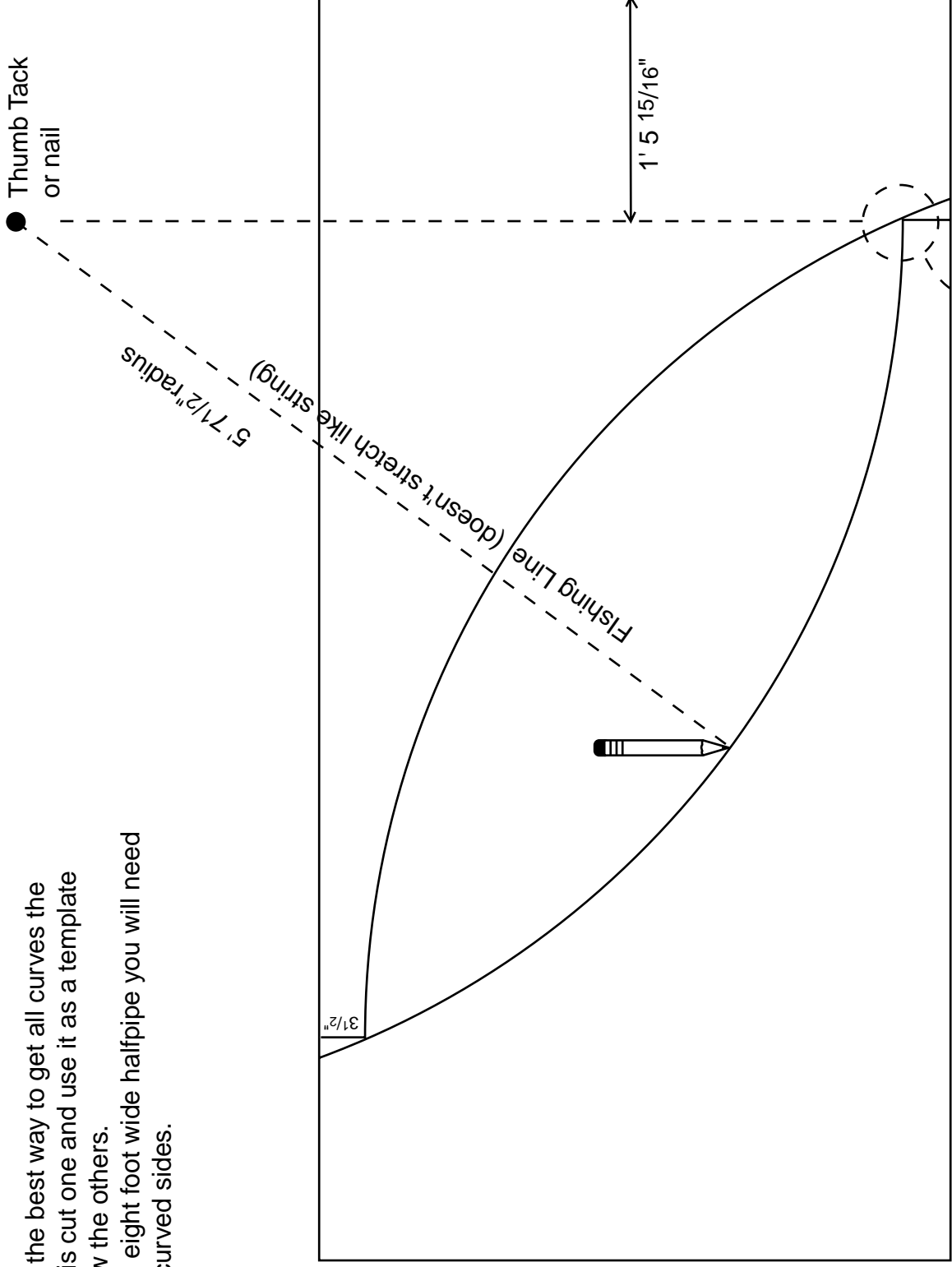

You may have to adjust the curve radius length to make sure you don't overlap here.

4 - 4 x 8 sheets of 3/4" plywood

CROSS JOIST POSITIONING (PLAN C)

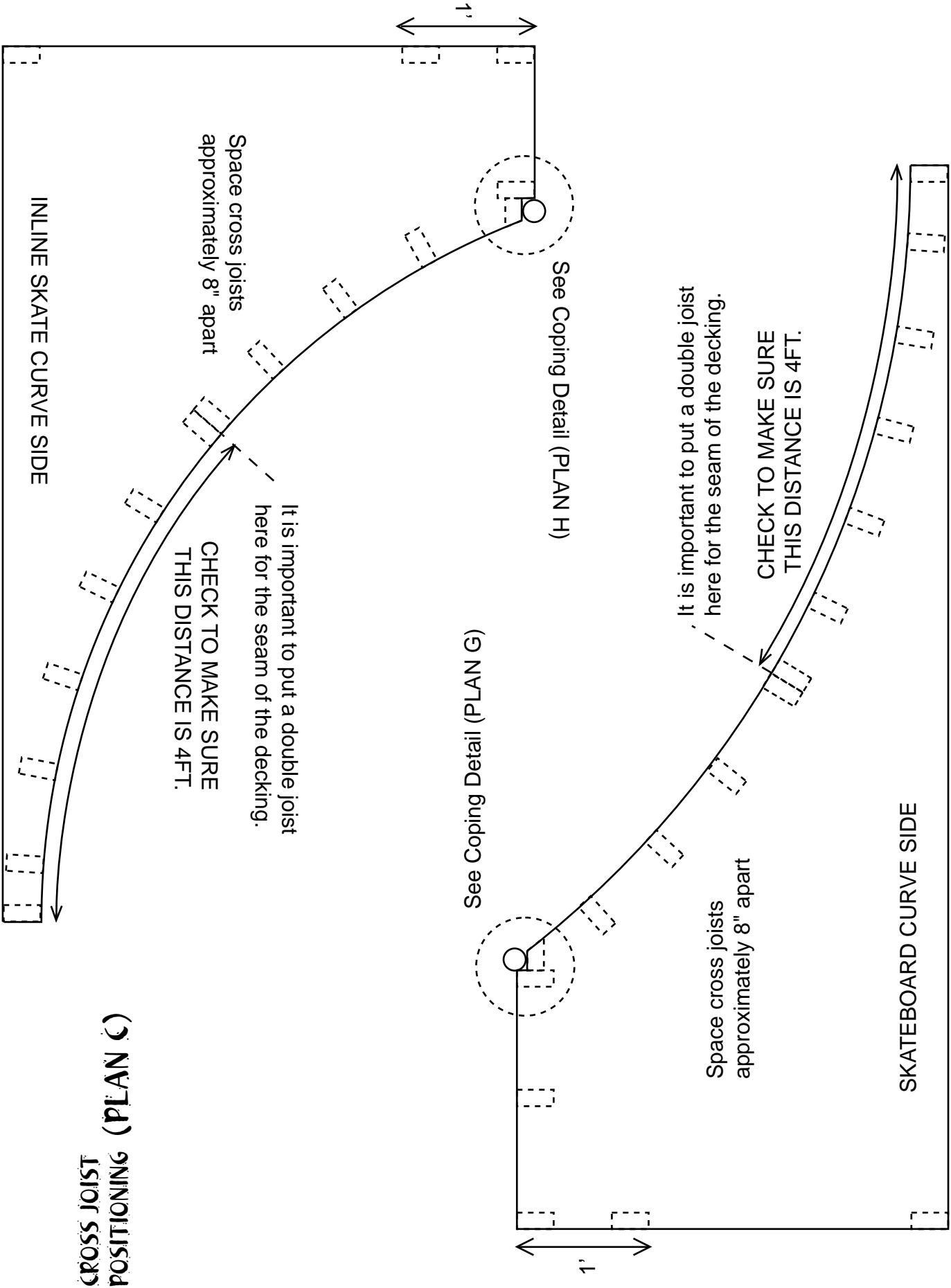

CURVED ENDS ASSEMBLY (PLAN D)

You will need 4 of these structures for your halfpipe

All measurements are exact, except where I refer to 2x4. This is a standard name for studs that are actually 1 1/2 x 3 1/2.

NOTE: Double Joist for plywood seam (See Cross Joist Positioning Plan C)

I used pressure treated 2x4's were they touched ground

15 - 2x4 x 46 1/2"
1 - 2x4 x 46 1/2" ripped at angle for coping edge (See Coping Detail Plan G or H)

See Coping Detail Plan G or H

Attach each 2x4 with two 3" galvanized wood screws (predrilling plywood helps)

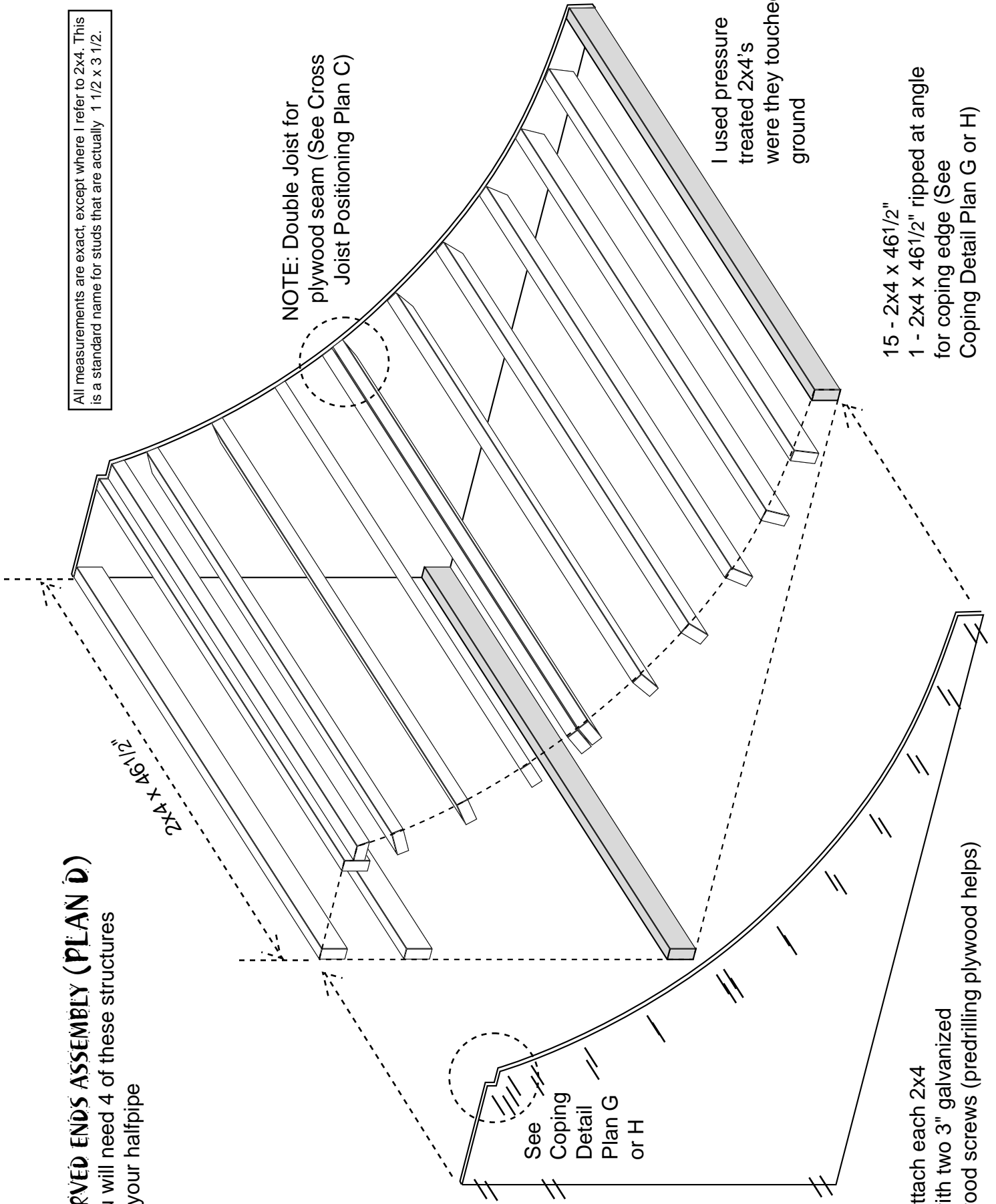

8' x 8' HALFPPIPE BOTTOM PLATFORM FRAMEWORK (PLAN E)

For unstable or slightly uneven ground

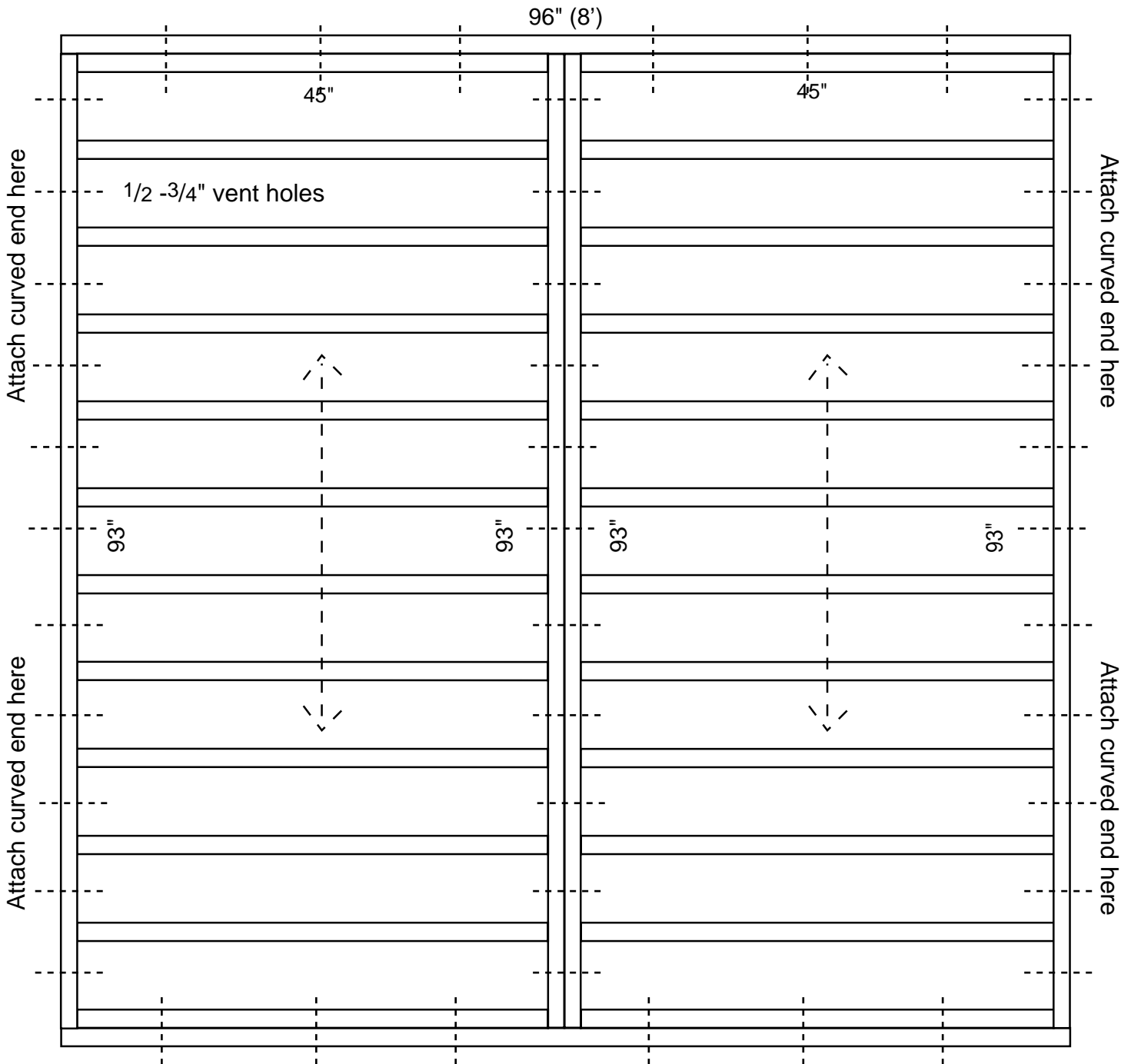

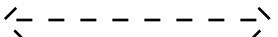
- 2 - 2"x4" x 96" (8')
- 4 - 2"x4" x 93"
- 24 - 2"x4" x 45" spaced approximately 8 3/8" apart
- 2 - 4'x8' x 3/4" plywood 

I made this frame work from pressure treated 2x4's and drilled vent holes in every row because I knew it would not get much air circulation under decking.

Assemble the two 4'x8' frames with two 3" galvanized wood screws at each end, then screw the two frames together to make an 8'x8' frame.

DO NOT PUT PLYWOOD ON TOP UNTIL THE CURVED ENDS HAVE BEEN ATTACHED.

All measurements are exact, except where I refer to 2x4. This is a standard name for studs that are actually 1 1/2 x 3 1/2.

8' x 8' HALFPipe BOTTOM PLATFORM FRAMEWORK (PLAN F)

For flat solid ground

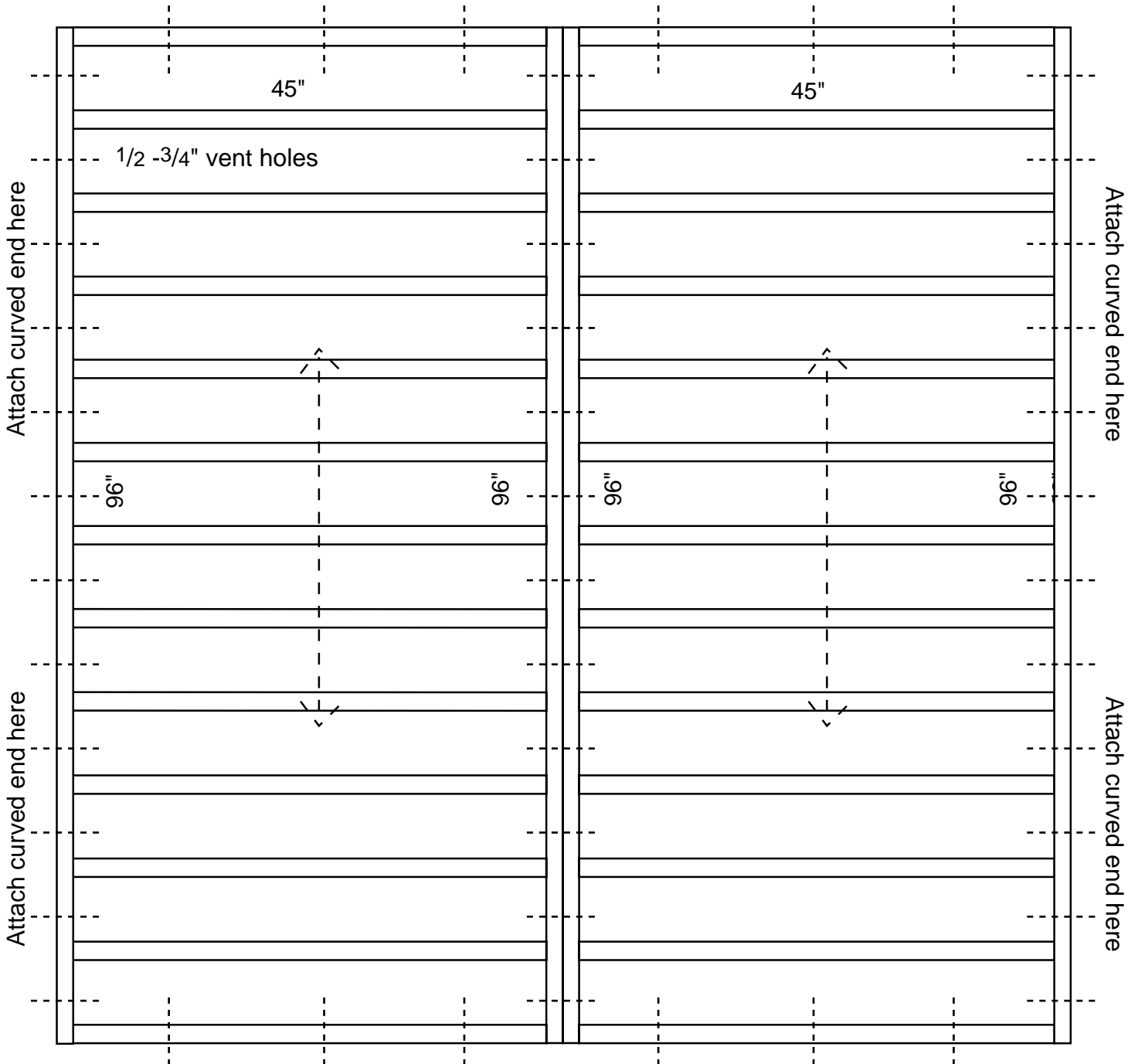

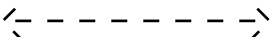
- 4 - 2"x4" x 96"
- 26 - 2"x4" x 45" spaced approximately 7 7/8" apart
- 2 - 4'x8' x 3/4" plywood 

I made this frame work from pressure treated 2x4's and drilled vent holes in every row because I knew it would not get much air circulation under decking.

Assemble the two 4'x8' frames with two 3" galvanized wood screws at each end, then screw the two frames together to make an 8'x8' frame
DO NOT PUT PLYWOOD ON TOP UNTIL THE CURVED ENDS HAVE BEEN ATTACHED.

All measurements are exact, except where I refer to 2x4. This is a standard name for studs that are actually 1 1/2 x 3 1/2.

(SKATEBOARD HALFPIPE) COPING FRAMING DETAIL (PLAN G)

This detail is actual size. You can use it to trace the notch for the coping.

Drill hole for size of screw through both sides of PVC pipe, Then enlarge top hole for screwdriver.
Use a screwdriver with a magnetized head.

- 2 - 1 1/2" ID Plastic PVC Pipe 8" long
- 16 - 1-1 1/2" Panhead Screws

Coping is approx. 1/2" above decking here.

Make sure coping is a little higher than decking here.

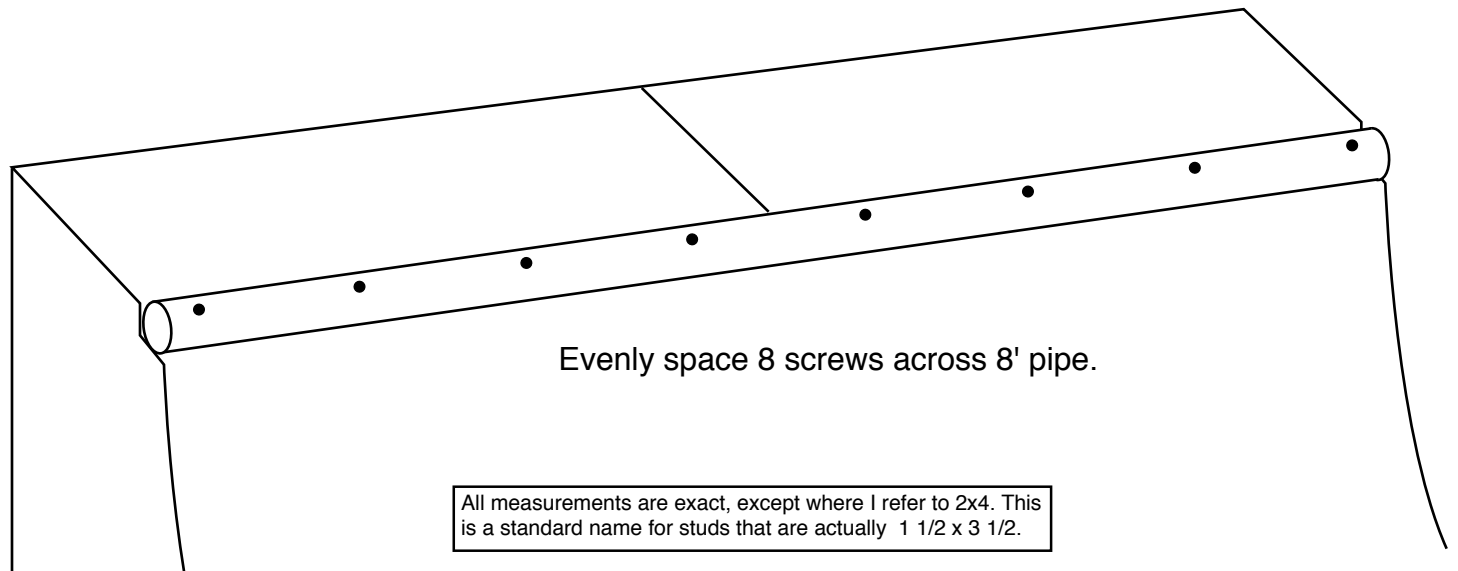
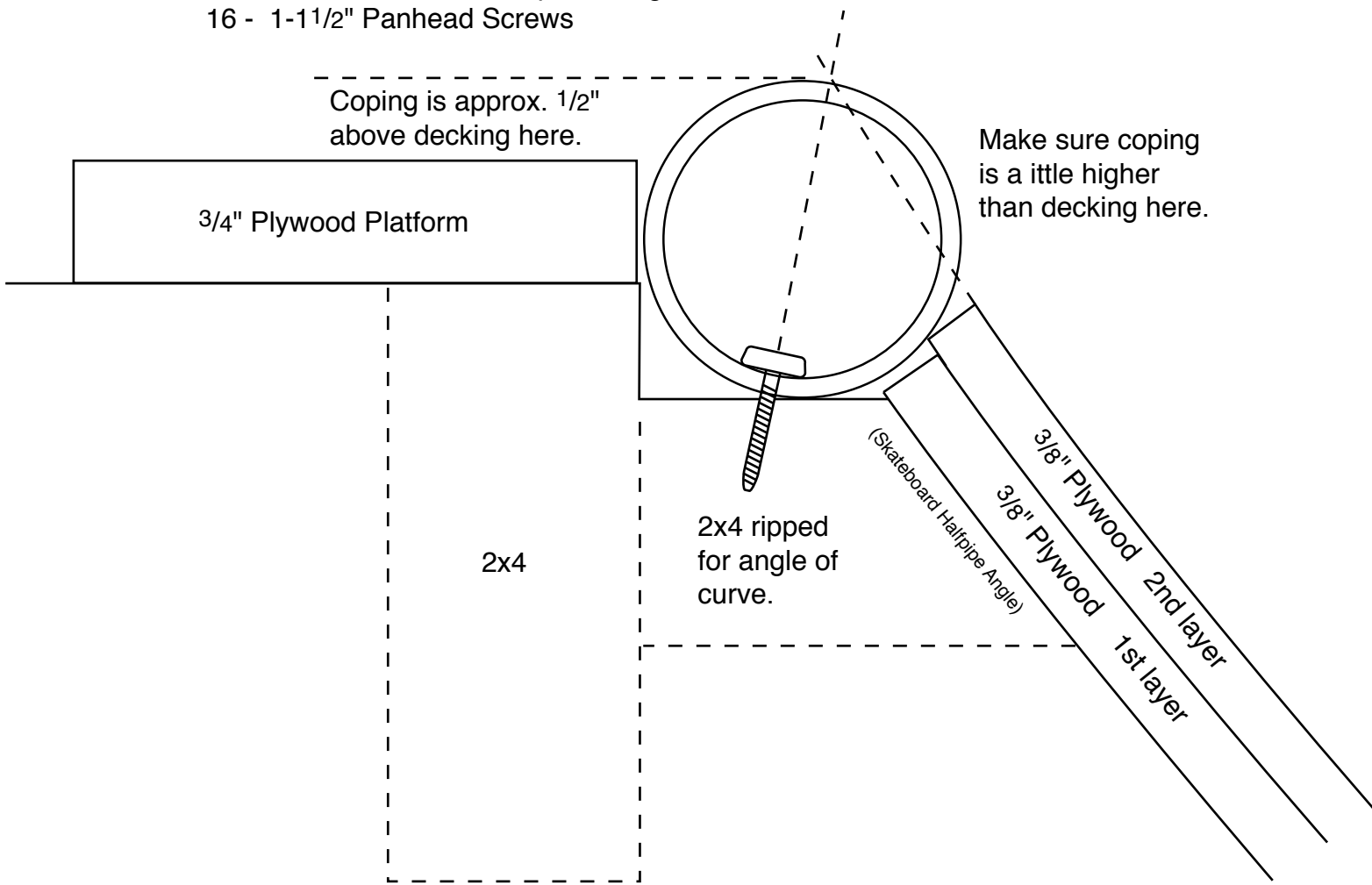

Evenly space 8 screws across 8' pipe.

All measurements are exact, except where I refer to 2x4. This is a standard name for studs that are actually 1 1/2 x 3 1/2.

(INLINE SKATE HALEPIPE) COPING FRAMING DETAIL (PLAN H)

This detail is actual size. You can use it to trace the notch for the coping.

- 2 - 1 1/2" ID Plastic PVC Pipe 8" long
- 16 - 1-1 1/2" Panhead Screws

Drill hole for size of screw through both sides of PVC pipe, Then enlarge top hole for screwdriver.
Use a screwdriver with a magnetized head.

Coping is approx. 1/2" above decking here.

Make sure coping is flush or lower than decking here.

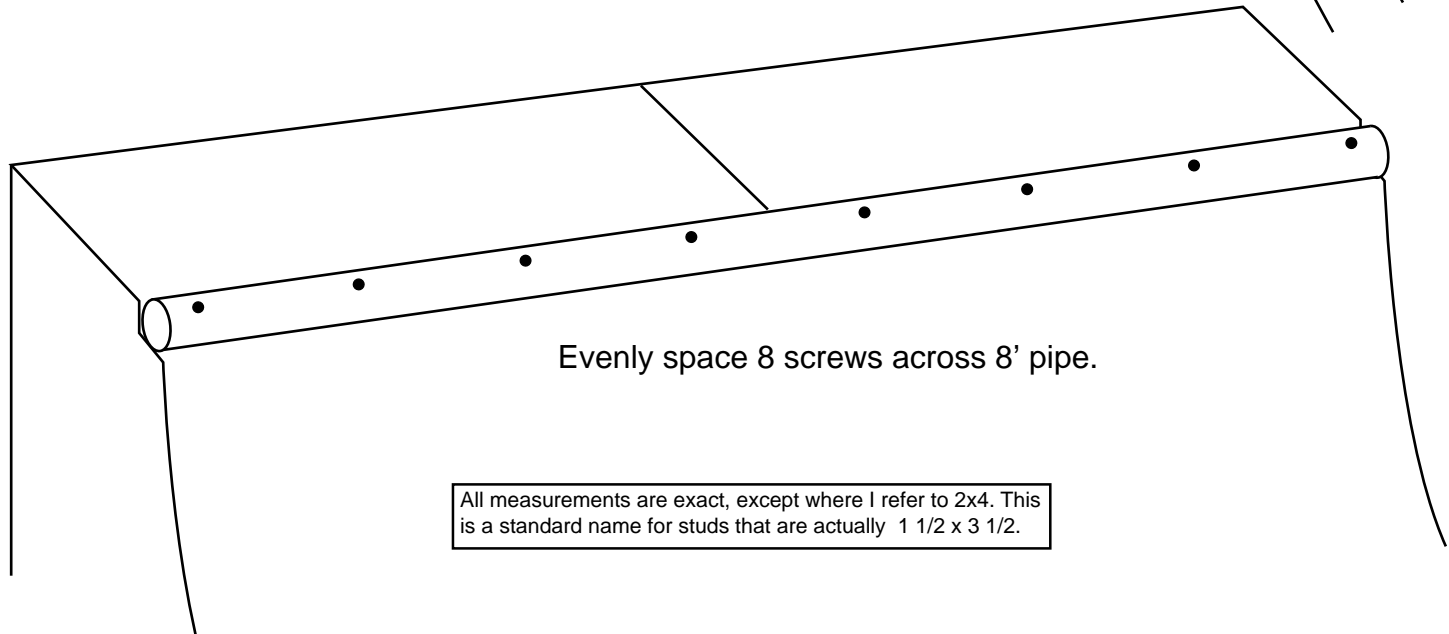
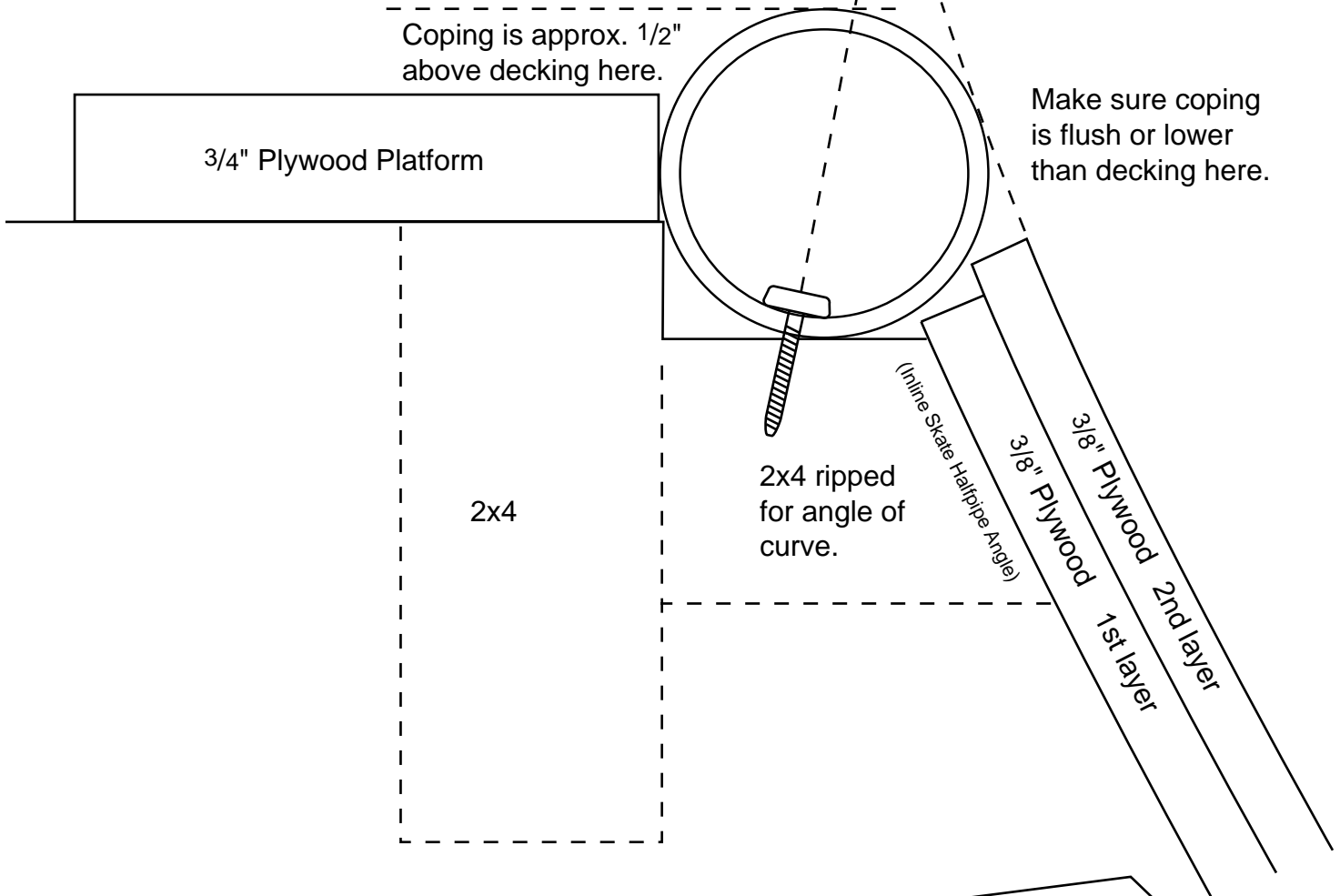

Evenly space 8 screws across 8' pipe.

All measurements are exact, except where I refer to 2x4. This is a standard name for studs that are actually 1 1/2 x 3 1/2.

COPING Optional Attachment DETAIL (PLAN H-6)

This detail is shown on the Inline coping version. Can be used on either version.

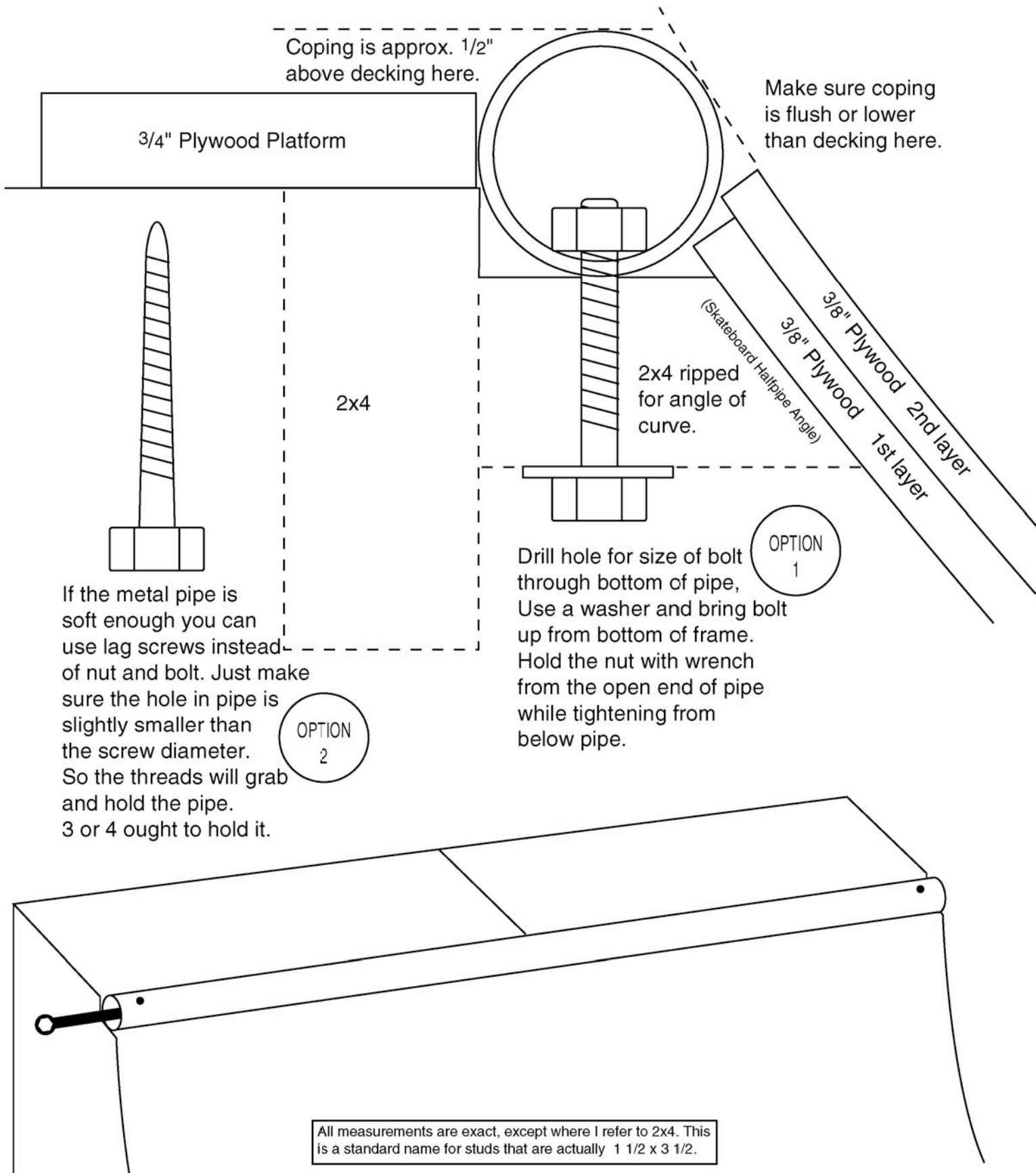

CURVED DECKING (PLAN J)

Material List is for both ends of halfpipe

1. 4- 4'x8' x 3/8"

2. 4- ?x8' x 3/8" (Cut width to fit)

WET BACK (UNFINISHED)

SIDE OF PLYWOOD

TO MAKE IT CURVE

3. 4- ?x4' x 3/4"

(Cut width to fit)

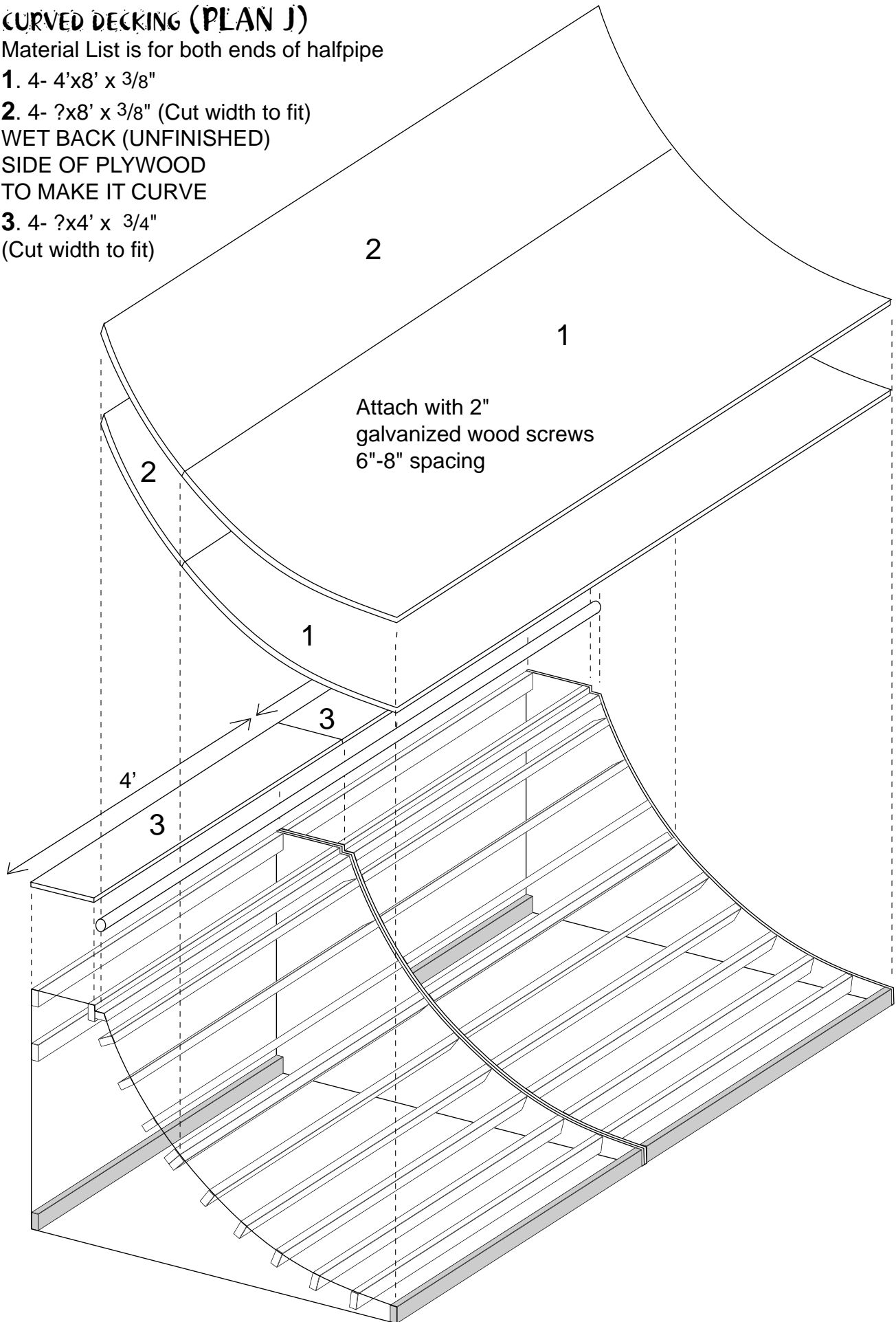

RAILING ASSEMBLY (PLAN K)

Material List is for both railings of halfpipe

- 6 - 2x4 x 8'
- 8 - 2x4 x 4'
- 16 - 1 1/4" Washers
- 16 - 3" Lag Screws

Use 3" galvanized wood screws for assembly at each crossover

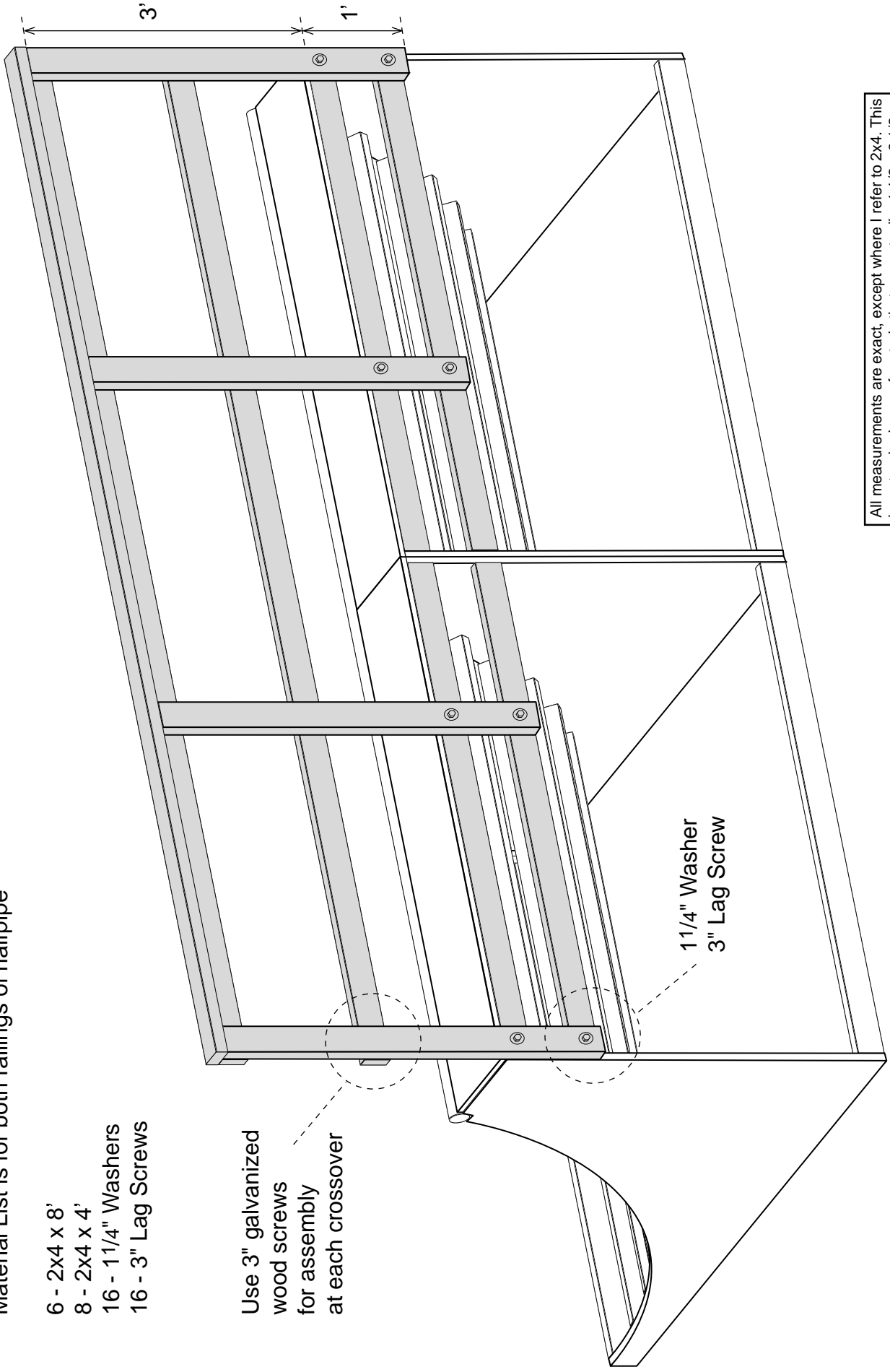

All measurements are exact, except where I refer to 2x4. This is a standard name for studs that are actually 1 1/2 x 3 1/2.

GRINDING RAIL PLAN

1 1/2" ID Plastic PVC Pipe 10" long
4 x 6 x 10' Wooden Beam
8 - 1 1/2" Panhead Screws

First cut the groove down the middle of the beam and bevel the edges. There is not an exact angle for the cuts, just don't make your groove cut too deep so the screws don't go into wood. I laid the PVC pipe on the ground and drilled my first eight holes from the top straight through the bottom being careful to keep the drill at the same angle for all the holes. The first drilling was just big enough for the screw to enter. I then redrilled just the top hole so I could get my screwdriver through the hole. With the PVC pipe in position using a MAGNETIC screwdriver I inserted the screw through the top hole down to the bottom hole into the wood.

